

SFP-1G-BX40-35

1000Base Bidirectional SFP
Tx 1310nm / Rx 1550nm
40km Reach

+45 (0)32 72 66 76



info@nexgen.eu



www.nexgen.eu



Features

- Support 1.25Gbps data links
- Hot-Pluggable LC connector
- Up to 40km on 9/125 μ m SMF
- 1310nm DFB laser transmitter
- 2x Bi-directional transceivers in 1 SFP metallic casing
- Single 3.3V power supply
- Monitoring Interface Compliant with SFF-8472
- Commercial Operating temperature : 0°C to 70°C
- Industrial Operating temperature : -40°C to 85°C
- Built-in digital diagnostic functions
- RoHS-6 compliant (lead-free)



Applications

- Gigabit Ethernet(1000BASE-BX)
- Point to Point FTTH Application
- Other optical transmission systems

Part number	Product description
SFP-1G-BX40-35	1000Base SMF SFP Bidi TX1310/RX1550 40km 0°C to 70°C LC Simplex DDM
SFP-1G-BX40-35-I	1000Base SMF SFP Bidi TX1310/RX1550 40km -40°C to 85°C LC Simplex DDM

PIN Description

PIN	Symbol	Name - Description	Notes
1	VEET	Transmitter Ground (Common with Receiver Ground)	1
2	TFAULT	Transmitter Fault. Not supported.	2
3	TDIS	Transmitter Disable. Laser output disabled on high or open.	3
4	MOD_DEF(2)	Module Definition 2. Data line for Serial ID.	2
5	MOD_DEF(1)	Module Definition 1. Clock line for Serial ID.	2
6	MOD_DEF(0)	Module Definition 0. Grounded within the module.	2
7	Rate Select	No connection required	
8	RX_LOS	Loss of Signal indication. Logic 0 indicates normal operation.	4
9	VEER	Receiver Ground (Common with Transmitter Ground)	
10	VEER	Receiver Ground (Common with Transmitter Ground)	1
11	VEER	Receiver Ground (Common with Transmitter Ground)	1
12	RD-	Receiver Inverted DATA out. AC Coupled	
13	RD+	Receiver Non-inverted DATA out. AC Coupled	
14	VEER	Receiver Ground (Common with Transmitter Ground)	1
15	VCCR	Receiver Power Supply	5
16	VCCT	Transmitter Power Supply	5
17	VEET	Transmitter Ground (Common with Receiver Ground)	1
18	TD+	Transmitter Non-Inverted DATA in. AC Coupled.	
19	TD-	Transmitter Inverted DATA in. AC Coupled.	
20	VEET	Transmitter Ground (Common with Receiver Ground)	1

Notes:

1. Circuit ground is internally isolated from chassis ground.
2. T_{FAULT} is an open collector/drain output, which should be pulled up with a 4.7k – 10k Ohms resistor on the host board if intended for use. Pull up voltage should be between 2.0V to V_{cc} + 0.3V. A high output indicates a transmitter fault caused by either the TX bias current or the TX output power exceeding the preset alarm thresholds. A low output indicates normal operation. In the low state, the output is pulled to <0.8V.
3. Laser output disabled on T_{DIS} >2.0V or open, enabled on T_{DIS} <0.8V.
4. LOS is open collector output. Should be pulled up with 4.7k – 10kΩ on host board to a voltage between 2.0V and 3.6V. Logic 0 indicates normal operation; logic 1 indicates loss of signal.
5. Internally connected



Figure 1. Diagram of host board connector block pin numbers and names

Absolute Maximum Ratings

Exceeding the limits below may damage the transceiver module permanently.

Parameter	Symbol	Min	Typ	Max	Unit	Ref.
Maximum Supply Voltage	V _{cc}	0		3.6	V	
Storage Temperature	T _S	-40		85	°C	
Relative Humidity	RH	0		85	%	1

Notes:

1. Non-condensing

Recommended Operating Environment

Parameter	Symbol	Min	Typical	Max	Unit
Case operating Com. Temp.	T _{op}	0		+70	°C
Case operating Ind. Temp.	T _{op}	-40		+85	°C
Supply Voltage	V _{cc}	3.135	3.30	3.465	V
Supply Current	I _{cc}		230	300	mA

Optical Characteristics

Parameter	Symbol	Min	Typical	Max	Unit	Note
Transmitter						
Center Wavelength	λ_c	1260	1310	1360	nm	
Spectral Width	σ	-	-	4	nm	
Optical Output Power	P _{out}	-3	-	+2	dBm	1
Extinction Ratio	ER	9	-	-	dB	
RMS Spectral Width (-20dB)	$\Delta\lambda$	-	-	1	nm	
Side Mode Suppression Ratio	SMSR	30	-	-	dB	
Receiver						
Optical Input Wavelength	λ_c	1530	1550	1570	nm	
Rx Sensitivity	P _{min}	-	-	-23	dBm	2
Rx Overload	P _{max}	-3	-	-	dBm	
LOS Assert	LOS _a	-45	-	-	dBm	
LOS De-Assert	LOS _d	-	-	-23.5	dBm	
LOS Hysteresis	LOS _h	0.5	-	-	dB	

Note:

1. Average Output Power as coupled into a 9/125 μ m single-mode fiber
2. Sensitivity is measured at 1.25Gbps PRBS 2-7-1 data pattern, ER=9, BER \leq 10⁻¹².

Mechanical Specifications

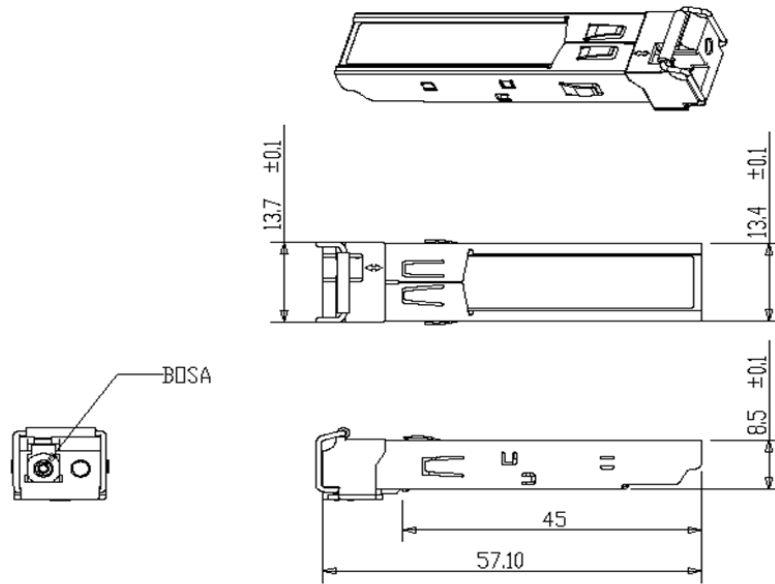

Revision history

Revision	Date	Author	Description
V1.1	25-11-2022	JGN	Initial Document

Note : Nexgen A/S reserves the right to change this document without notice.