

SFP-1G-Z160

1.25Gbps SFP
1550nm
160km Reach

+45 (0)32 72 66 76



info@nexgen.eu



www.nexgen.eu



Features

- Support up to 1.25Gbps data links
- 160km (37dB) transmission on 9/125µm SMF
- Duplex LC Connector Interface
- Hot-Pluggable Capability
- Compliant with SFP MSA and DDM interface SFF-8472
- Laser Class1, IEC60825-1 compliant
- Single +3.3V power supply and TTL logic interface
- Operating case temperature: Commercial: 0°C to +70°C
 Industrial: -40°C to +85°C
- RoHS6 Compliant



Applications

- Gigabit Ethernet / Fast Ethernet / OC-3 / OC-12
- Switch to Switch interface
- Other optical transmission systems

Part number	Product description
SFP-1G-Z160	1.25Gbps SFP, 1550nm, 160km/37dB, DDM, 0°C ~ +70°C
SFP-1G-Z160-I	1.25Gbps SFP, 1550nm, 160km/37dB, DDM, -40°C ~ +85°C

PIN Description

PIN	Symbol	Name - Description	Notes
1	VEET	Transmitter Ground (Common with Receiver Ground)	
2	TFAULT	Transmitter Fault. Not supported.	1
3	TDIS	Transmitter Disable. Laser output disabled on high or open.	2
4	MOD_DEF(2)	Module Definition 2. Data line for Serial ID.	1
5	MOD_DEF(1)	Module Definition 1. Clock line for Serial ID.	1
6	MOD_DEF(0)	Module Definition 0. Grounded within the module.	1
7	Rate Select	No connection required	
8	LOS	Loss of Signal indication. Logic 0 indicates normal operation.	3
9	VEER	Receiver Ground (Common with Transmitter Ground)	
10	VEER	Receiver Ground (Common with Transmitter Ground)	
11	VEER	Receiver Ground (Common with Transmitter Ground)	
12	RD-	Receiver Inverted DATA out. AC Coupled	4
13	RD+	Receiver Non-inverted DATA out. AC Coupled	4
14	VEER	Receiver Ground (Common with Transmitter Ground)	
15	VCCR	Receiver Power Supply	
16	VCCT	Transmitter Power Supply	
17	VEET	Transmitter Ground (Common with Receiver Ground)	
18	TD+	Transmitter Non-Inverted DATA in. AC Coupled.	5
19	TD-	Transmitter Inverted DATA in. AC Coupled.	5
20	VEET	Transmitter Ground (Common with Receiver Ground)	

Notes:

- Open collector/drain output, which should be pulled up with a 4.7kΩ to 10kΩ resistor on the host board if intended for use. Pull up voltage should be between 2.0V to 3.6V. A high output indicates a transmitter fault caused by either the TX bias current or the TX output power exceeding the preset alarm thresholds. A low output indicates normal operation. In the low state, the output is pulled to <0.8V.
- Laser output disabled on Tx_Disable >2.0V or open, enabled on Tx_Disable <0.8V.
- LOS is open collector output. Should be pulled up with 4.7kΩ to 10kΩ on host board to a voltage between 2.0V and 3.6V. Logic 0 indicates normal operation; logic 1 indicates loss of signal.
- RD-/+ : These are the differential receiver outputs. They are internally AC-coupled 100Ω differential lines which should be terminated with 100Ω (differential) at the user SERDES.
- TD-/+ : These are the differential transmitter inputs. They are internally AC-coupled, differential lines with 100Ω differential termination inside the module.



Figure 1. Diagram of host board connector block pin numbers and names

Absolute Maximum Ratings

Parameter	Symbol	Min	Typ	Max	Unit	Notes
Maximum Supply Voltage	V _{cc}	-0.5	-	5.0	V	
Storage Temperature	T _s	-40	-	+85	°C	
Relative Humidity	RH	5	-	95	%	1

Notes:

1. Non-condensing.

Recommend Operation Conditions

Parameter	Symbol	Min	Typ	Max	Unit	Notes
Power Supply Voltage	V _{cc}	3.13	3.3	3.47	V	
Power Supply Current	I _{cc}	-	-	110	mA	
Power Dissipation	P _o	-	-	1.0	W	
Case Operating Temperature (com.)	T _{op}	0	-	+70	°C	
Case Operating Temperature (ind.)	T _{op}	-40	-	+85	°C	

Electrical Characteristics

Parameter	Symbol	Min	Typ	Max	Unit	Notes
Transmitter						
Input Differential Impedance	Z _{in}	90	100	110	Ω	
Differential Input Voltage	V _{in}	600	-	1400	mV	
Receiver						
Output Differential Impedance	Z _{out}	90	100	110	Ω	
Differential Output Voltage	V _{out}	600	-	1400	mV	

Optical Characteristics

Parameter	Symbol	Min	Typ	Max	Unit	Notes
Transmitter						
Optical Center Wavelength	λ_C	1480	1550	1580	nm	
Average Output Power	P_o	3.0	-	7.0	dBm	
Optical Extinction Ratio	ER	9.0	-	-	dB	
RMS Spectral Width (-20dB)	$\Delta\lambda$	-	-	1	nm	
Data Rate	-	-	1.25	-	Gb/s	
Receiver						
Optical Center Wavelength	λ_C	1260	-	1620	nm	
Receiver Sensitivity	P_{min}	-	-	-34	dBm	
Receiver Overload	P_{max}	-3.0	-	-	dBm	
LOS De-Assert	LOSD	-	-	-24	dBm	
LOS Assert	LOSA	-45	-	-	dBm	
LOS Hysteresis	LOSH	0.5	-	-	dB	

Notes:
Sensitivity is measured at 1.25 Gbps with BER= $<10^{-12}$

Mechanical Dimensions

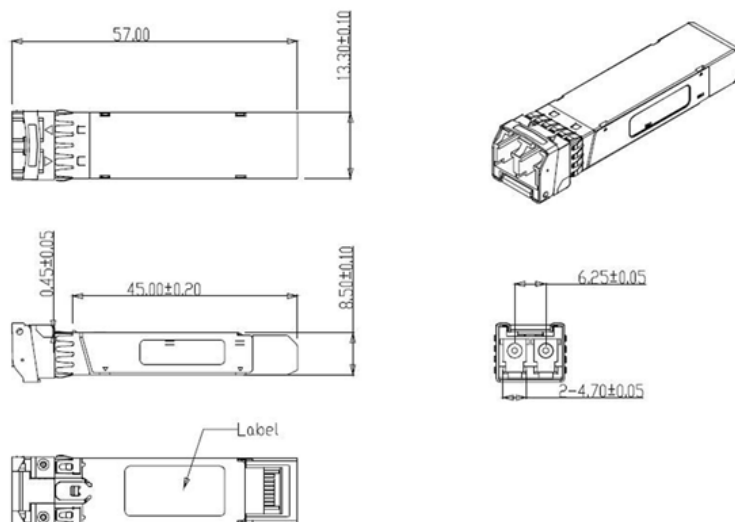

Revision history

Revision	Docs #	Date	Author	Description
V1.1	DT000064	05-03-2020	JGN	Initial Document
V1.2		02-07-2020	SHN	Minor Changes

Note : Nexgen A/S reserves the right to change this document without notice.