

SFP-1G-SX

1000Base SFP
850nm
550m Reach

+45 (0)32 72 66 76



info@nexgen.eu



www.nexgen.eu



Features

- Supports 1.25Gb/s Data Rate
- Up to 550m transmission on MMF
- 850nm VCSEL laser and PIN receiver
- Hot-pluggable SFP footprint
- SFI high speed electrical interface
- Built-in digital diagnostic functions
- Single +3.3V power supply
- Power consumption less than 1.0 W
- Commercial Operating Case Temperature: 0°C to 70°C
- Industrial Operating Case Temperature: -40°C to 85°C
- RoHS Compliant



Applications

- 1000BASE-SX/SW 1.25G Ethernet
- Other optical links

Part number	Product description
SFP-1G-SX	1000Base MMF SFP 850nm 550m 0°C to 70°C LC Duplex DDM
SFP-1G-SX-I	1000Base MMF SFP 850nm 550m -40°C to 85°C LC Duplex DDM

PIN Description

PIN	Symbol	Name - Description	Notes
1	VEET	Transmitter Ground (Common with Receiver Ground)	
2	TFAULT	Transmitter Fault. Not supported.	1
3	TDIS	Transmitter Disable. Laser output disabled on high or open.	2
4	MOD_DEF(2)	Module Definition 2. Data line for Serial ID.	1
5	MOD_DEF(1)	Module Definition 1. Clock line for Serial ID.	1
6	MOD_DEF(0)	Module Definition 0. Grounded within the module.	1
7	Rate Select	No connection required	
8	LOS	Loss of Signal indication. Logic 0 indicates normal operation.	3
9	VEER	Receiver Ground (Common with Transmitter Ground)	
10	VEER	Receiver Ground (Common with Transmitter Ground)	
11	VEER	Receiver Ground (Common with Transmitter Ground)	
12	RD-	Receiver Inverted DATA out. AC Coupled	4
13	RD+	Receiver Non-inverted DATA out. AC Coupled	4
14	VEER	Receiver Ground (Common with Transmitter Ground)	
15	VCCR	Receiver Power Supply	
16	VCCT	Transmitter Power Supply	
17	VEET	Transmitter Ground (Common with Receiver Ground)	
18	TD+	Transmitter Non-Inverted DATA in. AC Coupled.	5
19	TD-	Transmitter Inverted DATA in. AC Coupled.	5
20	VEET	Transmitter Ground (Common with Receiver Ground)	

Notes:

1. Open collector/drain output, which should be pulled up with a 4.7kΩ to 10kΩ resistor on the host board if intended for use. Pull up voltage should be between 2.0V to 3.6V. A high output indicates a transmitter fault caused by either the TX bias current or the TX output power exceeding the preset alarm thresholds. A low output indicates normal operation. In the low state, the output is pulled to <0.8V.
2. Laser output disabled on Tx_Disable >2.0V or open, enabled on Tx_Disable <0.8V.
3. LOS is open collector output. Should be pulled up with 4.7kΩ to 10kΩ on host board to a voltage between 2.0V and 3.6V. Logic 0 indicates normal operation; logic 1 indicates loss of signal.
4. RD-/+: These are the differential receiver outputs. They are internally AC-coupled 100Ω differential lines which should be terminated with 100Ω (differential) at the user SERDES.
5. TD-/+: These are the differential transmitter inputs. They are internally AC-coupled, differential lines with 100Ω differential termination inside the module.



Figure 1. Diagram of host board connector block pin numbers and names

Absolute Maximum Ratings

Parameter	Min	Typ	Max	Unit	Notes
Maximum Supply Voltage	-0.3	-	3.6	V	-
Storage Temperature	-40	-	+85	°C	-
Relative Humidity	5	-	85	%	1

Notes:

1. Non-condensing.

Recommend Operation Conditions

Parameter	Min	Typ	Max	Unit	Notes
Power Supply Voltage	3.135	3.3	3.465	V	-
Power Supply Current (com.)	-	-	250	mA	-
Power Supply Current (ind.)	-	-	250	mA	-
Case Operating Temperature (com.)	0	-	+70	°C	-
Case Operating Temperature (ind.)	-40	-	+85	°C	-

Electrical Characteristics

Parameter	Min	Typ	Max	Unit	Notes
Transmitter					
Input differential impedance	-	100	-	Ω	1
Single ended data input swing	250	-	1200	mV	-
TX Disable-High	V _{cc} -1.3	-	V _{cc}	V	-
TX Disable-Low	V _{ee}	-	V _{ee} +0.8	V	-
TX Fault-High	V _{cc} -0.5	-	V _{cc}	V	-
TX Fault-Low	V _{ee}	-	V _{ee} +0.5	V	-
Receiver					
Single ended data output swing	300	400	800	mV	2
Data output rise time	-	-	175	ps	3
Data output fall time	-	-	175	ps	3
LOS-High	V _{cc} -0.5	-	V _{cc}	V	-
LOS-Low	V _{ee}	-	V _{ee} +0.5	V	-

Notes:

1. AC coupled
2. into 100Ω differential termination
3. 20 - 80%

Optical Characteristics

Parameter	Min	Typ	Max	Unit	Notes
Transmitter					
Optical Center Wavelength	840	850	860	nm	-
Average Output Power	-9.0	-	-3	dBm	1
Optical Extinction Ratio	9.0	-	-	dB	-
RMS Spectral Width (-20dB)	-	-	0.85	nm	-
Rise/Fall Time	-	-	260	ps	2
Data Rate	-	1.25	-	Gb/s	-
Receiver					
Optical Center Wavelength	770	-	860	nm	-
Receiver Sensitivity	-	-	-17	dBm	3,4
Damage Threshold	0	-	-	dBm	-
LOS Assert	-35	-	-	dBm	-
LOS De-Assert	-	-	-18	dBm	-
LOS Hysteresis	0.5	-	-	dB	-

Notes:

1. Class 1 Laser Safety.
2. Unfiltered, 20-80%. Complies with GE.
3. Measured with conformance signals defined in FC-PI-2 Rev. 10.0 specifications.
4. Measured with PRBS 2-1 at 10⁻⁹ BER.

Mechanical Dimensions

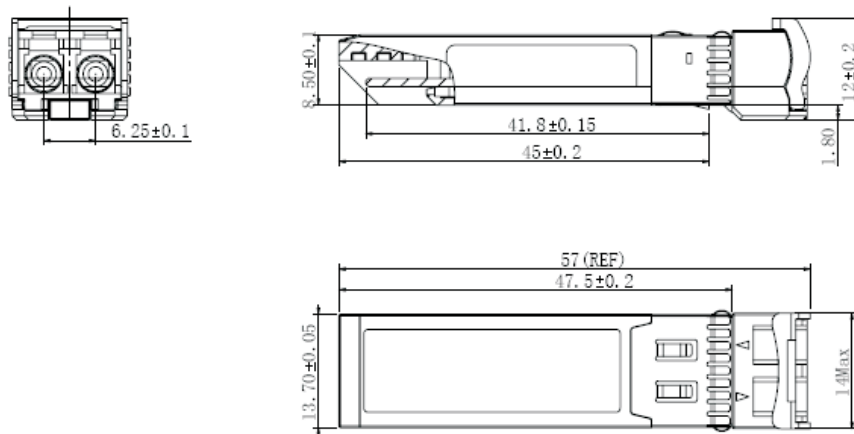

units : mm

Revision history

Revision	Date	Author	Description
V1.1	05-03-2020	JGN	Initial Document

Note : Nexgen A/S reserves the right to change this document without notice.