



QSFPDD-400G-XZRP

400GBase QSFP-DD
Tunable DWDM Coherent
Open ZR+ (EDFA)

Datasheet | product specifications

 ESD threshold 1kV for SFI pins and 2kV for all others electrical input pins, tested per MIL-STD-883G, Method 3015.4 /JESD22-A114A (HBM). However, normal ESD precautions are still required during the handling of this module.

 Class I Laser Product according to IEC 60825-1:2007. This product complies with 21 CFR 1040.10 and 1040.11 except for deviations pursuant to Laser Notice No. 50, dated (June 24, 2007). The optical ports of the module need to be terminated with an optical connector or with a dust plug in order to avoid contamination.



Features

- Supports DP-QPSK, DP-8QAM and DP-16QAM Modulation
- Compliant with OpenZR+ MSA technical specifications
- Hot pluggable QSFP-DD footprint (Type 2B)
- Interoperable Forward Error Correction (O-FEC & C-FEC)
- Line rate : 400/300/200/100Gb/s
- Client rate : 1/2/3/4x100Gb/s or 1x400Gb/s
- C-band tunable, supports 100/75/50GHz grid spacing
- Supports 0.1GHz fine turning
- High output Power EDFA + VOA embedded
- Up to 2000km reach on SMF
- LC-Duplex optical receptacle
- +3.3V power supply
- Power Dissipation < 22.5W (400Gb/s)
- Operating case temperature: 0°C to 70°C



Applications

- Edge DCI with extended Reach or with OLP protection
- IP Over Metro or Long Haul DWDM
- Up to 80Km (unamplified) 400G Point-to-Point link
- Up to 120km at 400G Gray Light mode (unamplified) 400G Point-to-Point link

Compliances

- Open ZR+ MSA2.0
- OIF-400ZR-0.2.0
- OIF-CMIS-05.2

Ordering information

Parameter	Product description
QSFPDD-400G-XZRP	400GBase SMF QSFP-DD Tunable DWDM Coherent EDFA OpenZR+ 0°C to 70°C LC Duplex DDM



PIN Description

Pin	Symbol	Function/Description	Notes
1	GND	Ground	1
2	Tx2n	Transmitter Inverted Data Input	
3	Tx2p	Transmitter Non-Inverted Data Input	
4	GND	Ground	1
5	Tx4n	Transmitter Inverted Data Input	
6	Tx4p	Transmitter Non-Inverted Data Input	
7	GND	Ground	1
8	ModSelL	Module Select	
9	ResetL	Module Reset	
10	VccRx	+3.3V Power Supply Receiver	2
11	SCL	2-Wire Serial Interface Clock	
12	SDA	2-Wire Serial Interface Data	
13	GND	Ground	1
14	Rx3p	Receiver Non-Inverted Data Output	
15	Rx3n	Receiver Inverted Data Output	
16	GND	Ground	1
17	Rx1p	Receiver Non-Inverted Data Output	
18	Rx1n	Receiver Inverted Data Output	
19	GND	Ground	
20	GND	Ground	1
21	Rx2n	Receiver Inverted Data Output	1
22	Rx2p	Receiver Non-Inverted Data Output	
23	GND	Ground	1
24	Rx4n	Receiver Inverted Data Output	
25	Rx4p	Receiver Non-Inverted Data Output	
26	GND	Ground	1
27	ModPrsL	Module Present	
28	IntL	Interrupt	
29	VccTx	+3.3V Power Supply transmitter	2
30	Vcc1	+3.3V Power Supply	2
31	LPMODE	Low Power Mode	
32	GND	Ground	1
33	Tx3p	Transmitter Non-Inverted Data Input	
34	Tx3n	Transmitter Inverted Data Input	
35	GND	Ground	1
36	Tx1p	Transmitter Non-Inverted Data Input	
37	Tx1n	Transmitter Inverted Data Input	
38	GND	Ground	1



39	GND	Ground	1
40	Tx6n	Transmitter Inverted Data Input	
41	Tx6p	Transmitter Non-Inverted Data Input	
42	GND	Ground	1
43	Tx8n	Transmitter Inverted Data Input	
44	Tx8p	Transmitter Non-Inverted Data Input	
45	GND	Ground	1
46	Reserved	For future use	3
47	Vs1	Module Vendor Specific 1	3
48	VccRx1	+3.3V Power supply	2
49	Vs2	Module Vendor Specific 2	3
50	Vs3	Module Vendor Specific 3	3
51	GND	Ground	1
52	Rx7p	Receiver Non-Inverted Data Output	
53	Rx7n	Receiver Inverted Data Output	
54	GND	Ground	1
55	Rx5p	Receiver Non-Inverted Data Output	
56	Rx5n	Receiver Inverted Data Output	
57	GND	Ground	
58	GND	Ground	1
59	Rx6n	Receiver Inverted Data Output	1
60	Rx6p	Receiver Non-Inverted Data Output	
61	GND	Ground	1
62	Rx8n	Receiver Inverted Data Output	
63	Rx8p	Receiver Non-Inverted Data Output	
64	GND	Ground	1
65	NC	No Connect	3
66	Reserved	For Future Use	3
67	VccTx1	+3.3V Power Supply Transmitter	2
68	Vcc2	+3.3V Power Supply	2
69	ePPS	Precision Time Protocol Reference Clock Input (not used)	3
70	GND	Ground	1
71	Tx7p	Transmitter Non-Inverted Data Input	
72	Tx7n	Transmitter Inverted Data Input	
73	GND	Ground	1
74	Tx5p	Transmitter Non-Inverted Data Input	
75	Tx5n	Transmitter Inverted Data Input	
76	GND	Ground	1

Notes:

1. QSFP-DD uses common ground (GND) for all signals and supply (power). All are common within the QSFP-DD module and all module voltages are referenced to this potential unless otherwise noted. Connect these directly to the host board signal-common ground plane.
2. VccRx, VccRx1, Vcc1, Vcc2, VccTx and VccTx1 shall be applied concurrently. VccRx, VccRx1, Vcc1, Vcc2, VccTx and VccTx1 may be internally connected within the module in any combination. The connector Vcc pins are each rated for a maximum current of 1000 mA.
3. All Vendor Specific, Reserved and No Connect pins may be terminated with 50 ohms to ground on the host. Pad 65 (No Connect) shall be left unconnected within the module. Vendor specific and Reserved pads shall have an impedance to GND that is greater than 10kOhms and less than 100 pF.



Pin Assignment and Description

38	GND			GND	76
37	TX1n			TX5n	75
36	TX1p			TX5p	74
35	GND			GND	73
34	TX3n			TX7n	72
33	TX3p			TX7p	71
32	GND			GND	70
31	LPMODE			ePPS	69
30	Vcc1			Vcc2	68
29	VccTx			VccTx1	67
28	IntL			Reserved	66
27	ModPrsL			NC	65
26	GND			GND	64
25	RX4p			Rx8p	63
24	RX4n			Rx8n	62
23	GND			GND	61
22	RX2p			Rx6p	60
21	RX2n			Rx6n	59
20	GND			GND	58

Card Edge

Top Side Viewed from Top

39	GND			GND	1
40	TX6n			TX2n	2
41	TX6p			TX2p	3
42	GND			GND	4
43	TX8n			TX4n	5
44	TX8p			TX4p	6
45	GND			GND	7
46	Reserved			ModSelL	8
47	Vs1			ResetL	9
48	VccRx1			VccRx	10
49	Vs2			SCL	11
50	Vs3			SDA	12
51	GND			GND	13
52	Rx7p			RX3p	14
53	Rx7n			RX3n	15
54	GND			GND	16
55	Rx5p			RX1p	17
56	Rx5n			RX1n	18
57	GND			GND	19

Card Edge

Bottom Side Viewed from Bottom

Absolute Maximum Ratings

Parameter	Symbol	Min	Typical	Max	Units
Power Supply Voltage	Vcc	-	-	3.6	V
Storage Temperature	TS	-40	-	85	°C
Relative Humidity	RH	5	-	85	%
Receiver Damage Threshold	PRdmg	-	-	10	dBm

Notes:
 Reaching any of the above limits may be harmful to the device



Recommended Operating Conditions

Parameter	Symbol	Min	Typical	Max	Units
Operating Case Temperature	Tc	0	-	70	°C
Power Supply Voltage	Vcc	3.13	3.3	3.46	V
Power Supply Current	Icc	-	-	7.5	A
Power Consumption @ 400Gb/s	PD	-	-	22.5	W
Power Consumption @ 4x 100Gb/s	PD	-	-	23.5	W
Relative Humidity	RH	15	-	85	%
Client Mode @ 400Gb/s (400ZR / ZR+)		1x 400GAUI-8 / 4x 100GAUI-2			
Client Mode @ 300Gb/s (300ZR+)		3x 100GAUI-2			
Client Mode @ 200Gb/s (200ZR+)		2x 100GAUI-2 / 2x CAUI-4			
Client Mode @ 100Gb/s (100ZR+)		1x 100GAUI-2 / 1x CAUI-4			
Reach @ 400Gb/s (400ZR)		-	-	120	Km
Reach @ 400Gb/s (400ZR+)		-	-	450	Km
Reach @ 300Gb/s (300ZR+)		-	-	600	Km
Reach @ 200Gb/s (200ZR+)		-	-	1000	Km
Reach @ 100Gb/s (100ZR+)		-	-	2000	Km
Power Supply Noise	Vrip	-	-	1% / 2%	DC-1MHz / 1-10MHz

Tx Optical Characteristics

Parameter	Min	Typical	Max	Units	Notes
Transmitter					
Modulation Format @ 400Gb/s	ZR400-CFEC-16QAM / ZR400-OFEC-16QAM				1 / 2
Modulation Format @ 300Gb/s	ZR300-OFEC-8QAM				2
Modulation Format @ 200Gb/s	ZR200-OFEC-QPSK				2
Modulation Format @ 100Gb/s	ZR100-OFEC-QPSK				2
Baud Rate @ 400Gb/s	59.843750000 / 60.138546798 ± 20ppm			GBd/s	3 / 4
Baud Rate @ 300Gb/s	60.138546798 ± 20ppm			GBd/s	5
Baud Rate @ 200Gb/s	60.138546798 ± 20ppm			GBd/s	6
Baud Rate @ 100Gb/s	30.069273399 ± 20ppm			GBd/s	7
Frequency Range	191.3	-	196.1	THz	
Flexible DWDM Grid	6.25	-	-	GHz	
Frequency Fine Tuning Range	-5	-	5	GHz	Bright Tuning
Frequency Fine Tuning Step	0.1	-	-	GHz	
Laser Frequency Accuracy	-1.8	-	1.8	GHz	
Laser Disable Time	-	-	100	ms	
Wavelength Switching Time	-	-	60	s	
Laser Enable Time	-	-	10	s	
Ouput Power Adjustable Range (300 / 400Gb/s)	-10	-	1	dBm	8
Ouput Power @ 400Gb/s 80km (gray)	3	4	5	dBm	@ 193.7 THz
Ouput Power Adjust Step	0.1	-	-	dB	



Optical Power Setting Accuracy	-1	-	1	dB	
Output Power Monitor Accuracy	-1	-	1	dB	
Power Stability (Room Temp.)	-0.5	-	0.5	dB	Fixed λ
Power Stability	-1	-	1	dB	Fixed λ
Total Output Power (Tx disabled)	-	-	-20	dBm	
Total Output Power (λ switching)	-	-	-20	dBm	
Reflectance	-	-	-20	dB	Looking in Tx
Inband (IB) OSNR	38	-	-	dB	
Lorentzian Linewidth	-	-	300	KHz	Tx & LO
Relative Intensity Noise	-	-	-140	dB/Hz	
Mean I-Q Amplitude Imbalance	-	-	1	dB	
Polarization Dependent Power	-	-	1.5	dB	
DC I-Q Offset	-	-	-26	dB	
I-Q Instantaneous Offset	-	-	-20	dB	

Notes:

1. CFEC FEC : 10.8dB Net Coding Gain
2. OFEC FEC : 11.6dB Net Coding Gain
3. SFF-8024 Media ID 3Eh/3Fh (400ZR)
4. SFF-8024 Media ID 46h (400ZR+)
5. SFF-8024 Media ID 47h (300ZR+)
6. SFF-8024 Media ID 48h (200ZR+)
7. SFF-8024 Media ID 49h (100ZR+)
8. The absolute accuracy is ± 1 dB

Rx Optical Characteristics

Parameter	Min	Typical	Max	Units	Notes
Receiver					
Modulation Format @ 400Gb/s	ZR400-CFEC-16QAM / ZR400-OFEC-16QAM				1 / 2
Modulation Format @ 300Gb/s	ZR300-OFEC-8QAM				2
Modulation Format @ 200Gb/s	ZR200-OFEC-QPSK				2
Modulation Format @ 100Gb/s	ZR100-OFEC-QPSK				2
Baud Rate @ 400Gb/s	59.843750000 / 60.138546798 \pm 20ppm			GBd/s	3 / 4
Baud Rate @ 300Gb/s	60.138546798 \pm 20ppm			GBd/s	5
Baud Rate @ 200Gb/s	60.138546798 \pm 20ppm			GBd/s	6
Baud Rate @ 100Gb/s	30.069273399 \pm 20ppm			GBd/s	7
Frequency Offset Between Carrier & LO	-3.6	-	3.6	GHz	
Input Power Range @ 400Gb/s	-12	-	0	dBm	8 / 9
Input Power Range @ 400Gb/s (80km gray)	-21	-	0	dBm	10
Input Power Range @ 300Gb/s	-15	-	0	dBm	11
Input Power Range @ 200Gb/s	-18	-	0	dBm	12
Input Power Range @ 100Gb/s	-18	-	0	dBm	13
OSNR Tolerance @ 400Gb/s	-	-	26 / 24	dB/0.1nm	ZR / ZR+, 14
OSNR Tolerance @ 300Gb/s	-	-	21	dB/0.1nm	ZR+, 14
OSNR Tolerance @ 200Gb/s	-	-	16	dB/0.1nm	ZR+, 14
OSNR Tolerance @ 100Gb/s	-	-	12.5	dB/0.1nm	ZR+, 14



Non-Damaging Input Power	-	-	10	dBm	
Optical Input Power Monitor Accuracy	-2	-	2	dB	
Max. FEC Pre BER	0.017	-	0.020		
Chromatic Dispersion @ 400Gb/s	-	-	2400 / 20000	ps/nm	ZR / ZR+, 15
Chromatic Dispersion @ 400Gb/s (80km gray)	-	-	2400	ps/nm	15
Chromatic Dispersion @ 300Gb/s	-	-	40000	ps/nm	ZR+, 15
Chromatic Dispersion @ 200Gb/s	-	-	50000	ps/nm	ZR+, 15
Chromatic Dispersion @ 100Gb/s	-	-	100000	ps/nm	ZR+, 15
DGD Tolerance @ 400Gb/s	33 / 66	-	-	ps	ZR / ZR+, 16
DGD Tolerance @ 300Gb/s	83	-	-	ps	ZR+, 16
DGD Tolerance @ 200Gb/s	83	-	-	ps	ZR+, 16
DGD Tolerance @ 100Gb/s	100	-	-	ps	ZR+, 16
Peak PDL Tolerance	-	-	3 / 3.5	dB	17 / 18
Tolerance to Change in SOP	50	-	-	krad/s	19
Optical Return Loss	20	-	-	dB	20
LOS Assert @ 400Gb/s	-20	-18	-16	dBm	
LOS Assert @ 400Gb/s (80km gray)	-28	-26	-24	dBm	
LOS Assert @ 300Gb/s	-23	-21	-19	dBm	
LOS Assert @ 200Gb/s	-26	-24	-22	dBm	
LOS Assert @ 100Gb/s	-26	-24	-22	dBm	
LOS Hysteresis	1	1.5	2.5	dB	

Notes:

- 1. CFEC FEC : 10.8dB Net Coding Gain
- 2. OFEC FEC : 11.6dB Net Coding Gain
Thretical Max Pre FEC BER 2×10^{-2}
- 3. SFF-8024 Media ID 3Eh/3Fh (400ZR)
- 4. SFF-8024 Media ID 46h (400ZR+)
- 5. SFF-8024 Media ID 47h (300ZR+)
- 6. SFF-8024 Media ID 48h (200ZR+)
- 7. SFF-8024 Media ID 49h (100ZR+)
- 8. Signal power, OSNR > 26dB (400ZR)
- 9. Signal power, OSNR > 24dB (400ZR+)
- 10. Signal power, OSNR > 34dB
- 11. Signal power, OSNR > 21dB (300ZR+)
- 12. Signal power, OSNR > 16dB (200ZR+)
- 13. Signal power, OSNR > 12.5dB (100ZR+)
- 14. Measured back-to-back with short optical channel
- 15. Tolerance to CD with ≤ 0.5 dB penalty to OSNR sensitivity when change in SOP is ≤ 1 rad/ms
- 16. OSNR penalty < 0.5dB
- 17. Tolerance to peak PDL with ≤ 1.3 dB additional OSNR penalty when change in SOP is ≤ 1 rad/ms
- 18. Tolerance to peak PDL with ≤ 1.8 dB additional OSNR penalty when change in SOP is ≤ 1 rad/ms
- 19. With ≤ 0.5 dB additional OSNR penalty over all PMD and PDL values
- 20. Optical reflectance at Rx connector input

Transceiver Block Diagram

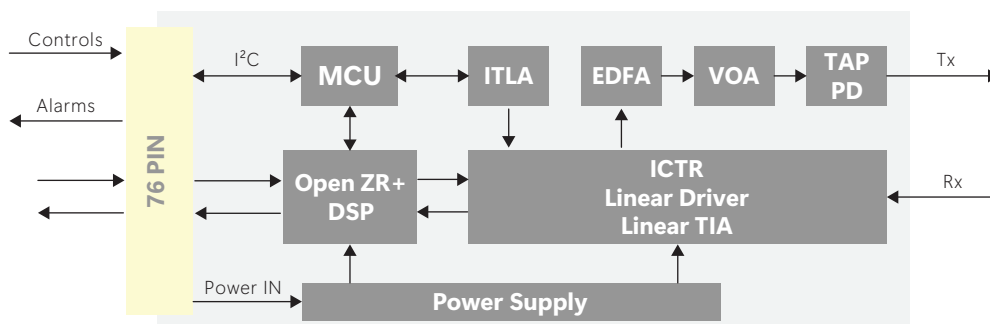

QSFPDD-400G-XZRP+ Block Diagram



Mechanical Specifications

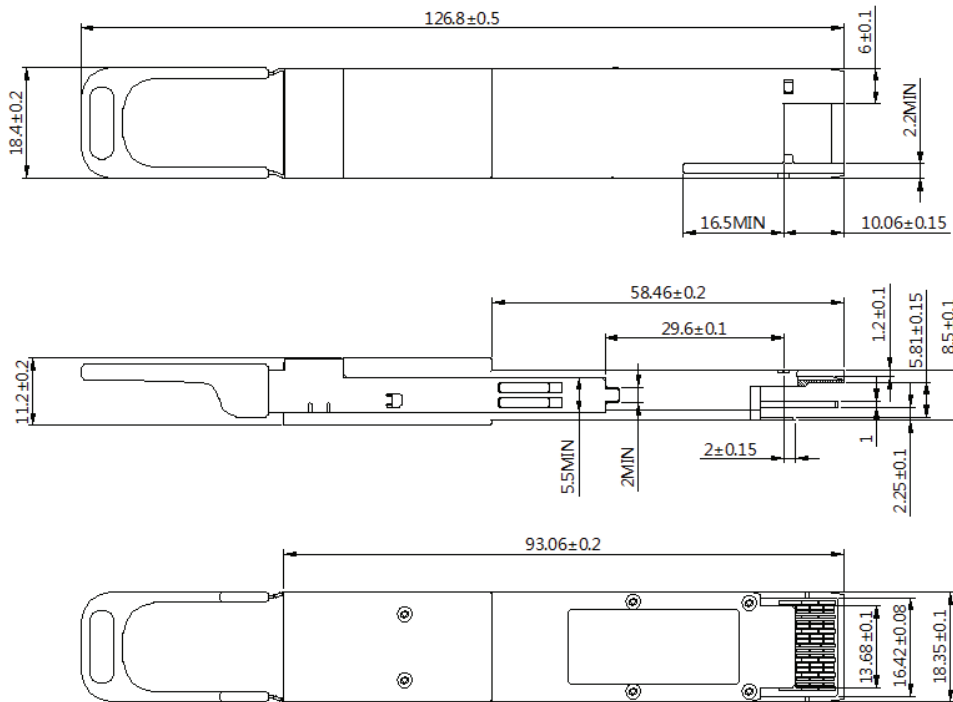

Unit : Millimeters

Revision History

Revision	Date	Author	Document
V1.0	14-05-2023	JGN	N/A

Note :
 Nexgen A/S reserves the right to change this document without notice.